

Achieving High Performance: A Collaborative Approach for Motion Control Solutions

Robert Luong

Moog
Marketing Manager

Key Messages

- Motion control requirements grow more demanding and more complex.
- More engineers are turning to expert partners for high-performance motion control solutions.
- A true motion control solution offers machine builders not just servomechanisms but real business benefits (productivity, machine life) at a whole new level.

Summary

The increasing demands of machine automation pose a unique challenge to the engineers who are responsible for motion control. New requirements may demand an even faster machine with greater fidelity control, higher power delivery or improved efficiency. These often conflicting problems are difficult for engineers to solve even with the improved technologies at their disposal.

A traditional approach towards motion control is not always sufficient to meet these challenges, so engineers in a growing number of fields are seeking specialized expertise. To be successful, engineers often need to engage in deep, broad partnerships with motion control experts who demonstrate application knowledge, a willingness to adapt, flexibility, innovation, global presence and business expertise.

Achieving High Performance: A Collaborative Approach for Motion Control Solutions, describes engineers successfully solving some of the most intractable motion control problems in their industries by engaging in close partnership with Moog Industrial. The paper also describes the advantages and disadvantages of traditional approaches, the role of an expert partner in designing a solution, what to look for in such a partner, and how to create motion control solutions that result in real competitive differentiation. Finally, it offers application examples and a technical example of the successful outcome of a partnership between a machine builder and Moog Industrial in delivering a truly innovative motion control solution.



1 The Challenge of Motion Control

1.1 High-Performance Applications for Motion Control

The essence of control engineering is to manipulate the dynamic conditions under which a mechanical system must deliver high performance. Engineers must reconcile mutually exclusive requirements, whether moving an actuator accurately and building up sufficient force to keep it in position, or negotiating the trade-off between the frequency/fidelity of a small drive and the flow/power of a large drive. “High-performance” applications sometimes test long-standing laws of engineering, and have serious consequences (destruction of machinery or property, loss of life) in case of failure.

In addition to the technical imperatives, these applications have business-imperatives which may be critical in defining the appropriate motion control solution. For example, the application may need to increase productivity, improve quality or use expensive raw materials efficiently.

1.2 Electro-hydraulic and Electro-mechanical

Motion control applied traditionally to a limited set of servo-products. It continued to evolve to include a wide range of products such as servovalves, servomotors, servodrives, control electronics control software, even digital valves and pumps with on-board intelligence. Motion control is now an industrial specialty, and engineers must choose among many technologies for controlling motion. Electro-hydraulic (EH, or “hydraulic”) components generally dominate applications that require high power-density. Electro-mechanical (EM, or “electric”) components are generally preferred in applications that require on-demand response, high energy efficiency, and high precision along with lower operating costs. Which technology to use has long been a topic of various discussions among motion control engineers, with proponents of each discipline arguing

High-performance motion control parameters include:

- Minimum cycle times
- Rapid configuration change for just-in-time manufacturing
- Robustness of design/reliability
- Accuracy
- Consistency, repeatability
- Durability
- Minimum disruption of production
- Right-the-first-time commissioning
- Severe consequences of failure

the case for EM or EH technology.

Table 1 shows a traditional comparison of major advantages and disadvantages for both technologies. As engineers push the limits of each technology and new options emerge, this debate will continue to evolve.

While many engineers still define motion control by individual products and specific technologies, (e.g., electro-hydraulic vs. electro-mechanical), there is an increasing trend towards defining a solution that meets the specific needs of each application. This trend has become particularly evident in high-performance motion control applications. High-performance motion control often goes beyond the components and the choice of technology. The prevalence of hybrid solutions combining electro-hydraulic and electro-mechanical technologies provides further evidence of engineers changing their approach to high-performance motion control.

| ELECTRO-HYDRAULIC | | ELECTRO-MECHANICAL | |
|--|--|---|--|
| ADVANTAGES | DISADVANTAGES | ADVANTAGES | DISADVANTAGES |
| <ul style="list-style-type: none"> • High peak acceleration • Smaller actuator • Durable actuator • One moving part • Power line averaging (accumulators) • High power capacity (load/speed combination) | <ul style="list-style-type: none"> • Potential for leaks of hazardous fluid • Installation of hydraulic power unit (HPU) – footprint, noise, heat, maintenance, plumbing • Less efficient power consumption | <ul style="list-style-type: none"> • Clean operation • Smaller footprint • More efficient power consumption • Lower heat generation • Simpler installation procedure | <ul style="list-style-type: none"> • Limited acceleration • More complex actuator • More complex fail-safe mechanism • More complex electronics • Peak power demands not manageable by power line averaging • Control of high forces |

Table 1 – Traditional Comparison, Electro-hydraulic and Electro-mechanical Motion Control Technologies

2 Current Approaches to Motion Control

The best approach to implementing motion control depends on the complexity of the application. For example, catalog purchasing with minimal engineering consultation often suffices for lower-performance applications. High-performance applications, however, call for greater expertise and collaboration.

2.1 Catalog Purchasing

Catalog purchasing for standard components plays a prominent role in applications and environments where low cost takes precedence over performance. It is not critical to match an exact component to a set of unique specifications in these applications. Redesign of existing components offers minimal performance improvement, so buyers need little involvement with part suppliers.

Such an approach may be appropriate in extending the useful life of an existing engineering solution, but it may not necessarily be the lowest-cost solution for new designs with high-performance criteria.

2.2 High-end, Customized Product Development

High-end, customized product development has the potential to take the customer's machine to next level by, for example, combining standard components and their functions to reduce the number of parts needed. Many customers know which component to use but require some product customization for optimal functionality.

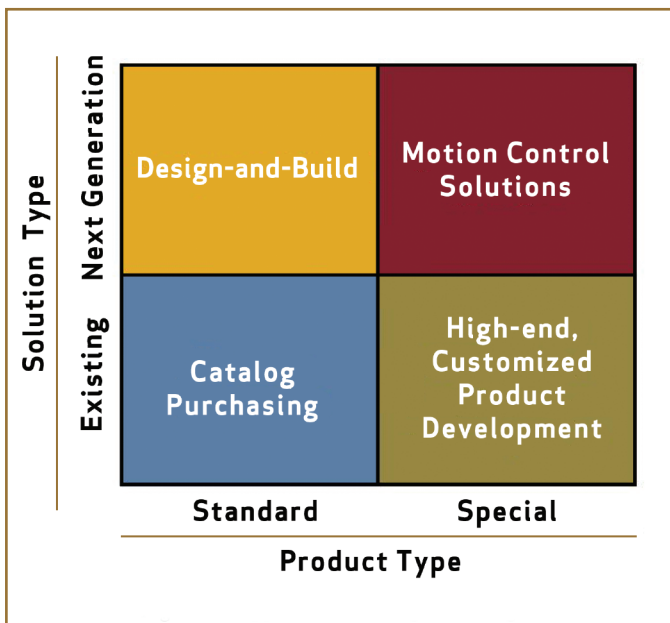

Figure 1 – Approaches to Design Challenge

Customers who meet their motion control needs using this approach are willing to buy an intellectual supplement to their hardware purchase, to help achieve long-term improvements in performance and productivity. They look to their vendor as a source of information as well as components and are willing to share a certain, limited amount of proprietary information about their requirements and specifications. However, they are not willing to incur the investment and risk of a close partnership, and therefore do not realize strong competitive differentiation or reap the benefits of the full range of their vendor's expertise.

2.3 Design-and-Build

Some engineers seeking high performance embark on a significant design-and-build effort to shape the machine around existing or customized components. In this approach, the engineer often leads the in-house design process, sources standard components and engages an expert vendor for product customization.

This approach can result in cost-effective improvement to the machine's performance. However, scarcity of domain expertise in high-performance motion control results in a greater risk of the solution not meeting the requirements, and the design-and-build project may fall short of its objective.

2.4 Motion Control Solutions

To get around all of these issues, engineers in some industries have begun to favor complete motion control solutions in which they begin collaborating with an expert partner in the early stages of their projects. This allows for both solid innovation from the start and comprehensive follow-through at every project phase. These engineers understand the value of not only the components and design, but also the provider's involvement and expertise.

The advantages of cooperating toward a motion control solution include the opportunity to achieve performance goals through competitive differentiation; a deeply collaborative relationship with the provider; design, production and support from a single source; and shared risk in the outcome.

However, it can be difficult to find all of these attributes in a single partnering company, and even with such a partner in hand, achieving this level of quality often requires a substantial investment of time and money.

2.5 Market Trends and New Thinking

There are some important drivers which are changing the priorities and focus of machine builders facing motion control problems.

- **Rising Energy Costs** – End use customers facing more expensive energy may move to acquiring machines with the latest components and techniques rather than continually repairing and upgrading old, inefficient machines.
- **Environmental Pressure** – Recent surges in industrial output and resource consumption in developing nations demand not only greater productivity of machines, but less noise and lower environmental impact.
- **More-Specialized Machines** – Particularly in high-performance applications, the subtle know-how that leads to increased profit margins requires a deep understanding of the machine and the flexibility to customize components.
- **Increasing Machine Safety Standards** – Manufacturers need to meet government-imposed safety criteria such as European Community directives, TÜV (the German safety and standards institution) specifications and machine guarding standards.

- **Rapidly Changing Technology** – From changes in microprocessor operating speeds to upgrades in materials, technical advances make previously unattainable levels of performance possible. The first-mover advantage is a strong incentive to try out the latest machine designs from a supplier; conversely, if a company's designs are dependent on obsolete technology, it will quickly lose out to far-sighted competitors.

Forward-thinking engineers are looking for a partner to help them cope with these drivers.

High-Performance Motion Control Market Drivers and Trends

- Rising Energy Costs
- Environmental Pressure
- More Specialized Machines
- Increased Machine Safety Standards
- Rapidly Changing Technology
- Willingness to Invest in High-Performance Solutions for Competitive Advantage
- Preference for Collaboration, Not Just Components
- Focus on Outcomes Rather than on Choice of Technology

Application Highlight - Flight Simulation



| | |
|--------------------------------------|--|
| Customer | FlightSafety International Inc. |
| Application | Flight training simulates a growing range of aircraft, from very light jets and helicopters to wide-body airplanes. A motion base, controller and control loader move and support a 10,000 kg pod. The manufacturer wanted first-mover advantage by developing an all-electric motion base and controller. |
| Requirements | High uptime, low noise, extremely high fidelity to in-cockpit avionics and digital display technology |
| Prevalent Technology | Hydraulic, evolving to electro-mechanical |
| Challenge | Designers had traditionally relied on hydraulic technology in the motion base and avoided electro-mechanical because of the high weight of the payload and the need for smooth response. Hydraulic motion bases are quiet but not energy-efficient, so the electro-mechanical product had to run with minimal audible noise and demonstrate lower operating costs. |
| Solution | Moog and the manufacturer collaborated on the industry's first all-electric motion base, built around brushless servomotors and servodrives, new ball screw technology for smoother performance, and Ethernet/Firewire protocols. The motion base is capable of 60-inch strokes and 10,000kg of payload, and is equipped with safety systems and motion cueing software for 16-bit accuracy. |
| Benefits to OEM and end users | Besides dramatic improvements in uptime and the environmental advantage of oil-free operation, the manufacturer realized 70-85% energy savings over hydraulic systems. The resulting flight simulation was so realistic that the manufacturer's flight training program received Level D certification from the Federal Aviation Administration (FAA), allowing trainees to accumulate the required amount of flight time to qualify for a flight license. |
| For More Information | Subscribe at www.info.moog.com for entire case study. |

3 Motion Control Solution Provider - What to Look For

Depending on their needs, engineers may seek certain characteristics and results to bridge the motion-control gap between the present and the future.

- Outside perspective on technical and commercial aspects of the problem – Providers who meet this need undertake a detailed review of the existing machine and necessary improvements. They understand the customer’s technical and business requirements and include the customer in a **Structured, Partnership-Oriented Engagement**.
- Competitive advantage through one-of-a-kind products – This need compels many manufacturers to seek a high-end partner. It requires **Willingness to Adapt** in a provider who can use analytical and simulation tools to tailor existing components to the needs of the machine and envision solutions beyond commercial-off-the-shelf (COTS) parts.
- Use today’s technology while incorporating tomorrow’s – OEMs want their investments in solutions for current applications to pay off in future applications as well. The provider who focuses on the outcome instead of recommending a preferred technology brings **Innovation and Flexibility**.
- Global knowledge base and support – Only providers who deploy and support products worldwide can draw on experience and know-how from all over the engineering universe and offer their customers **Worldwide Reach**.
- Long-term growth of product and business lines – By thinking beyond actuators and servomechanisms to the optimal motion or product the machine delivers, the provider with **Business Expertise** designs with the next generation of his customer’s machines in mind.

Application Highlight - Metal Forming

| | |
|--------------------------------------|--|
| Customer | Dorst Technologies |
| Application | Powder presses shape complex metal or ceramic parts for the automotive and electronics industries, and for high-end, designer appliances. |
| Requirements | High accuracy, short cycle times, tight tolerance for produced parts, high level of force |
| Prevalent Technology | Hydraulic |
| Challenge | Engineers sought a way to increase speed for rapid movement of the main press axis in conjunction with a fast and smooth transition to press speed, and reduce cycle time. The new solution had to reduce energy consumption and deliver position accuracy of < 0.01mm at the tool axes. |
| Solution | Working with Moog, the manufacturer developed multi-axis, continuous path control of the tool axes for high rates of response and accuracy. The solution features hydraulic manifold blocks with optimized hydraulic circuits for the main press axis and the tool axes. |
| Benefits to OEM and end users | Powder presses equipped with the new solution are demonstrating up to 50% in energy savings. The higher and more consistent productivity of the presses has resulted in greatly lowered the scrap rate. |
| For More Information | Subscribe at www.info.moog.com for entire case study. |

4 Moog Solution Application Example - Power Generation

The Moog Solution embodies all of the characteristics sought by demanding engineers in a high-performance motion control provider. As the following power generation example demonstrates, the customer’s willingness and ability to collaborate deeply with Moog can result in real competitive advantages.

4.1 Background and Challenges - Gas Turbines

Operating parameters of a gas turbine are controlled through the opening and closing of a valve outlet. In case of an emergency shut-down that is initiated by the central turbine controller, the valve must switch to safe-mode and dynamically close against the gas pressure to protect the turbine from severe, costly damage. The industry-standard approach is to use a spring for fail-safe closure of the valve. In hydraulically operated valves this spring is maintained in constant compression whether in normal or safe mode.

To move beyond the long-standing technical limitations of this approach (see sidebar “Power Generation Application-Technical Challenges”), this turbine manufacturer had set both internal and external resources to the task of building a safe, industry-leading electro-mechanical solution, but without success. Ultimately, the manufacturer sought Moog’s expertise in motion control and familiarity with power generation applications for an improved valve design.

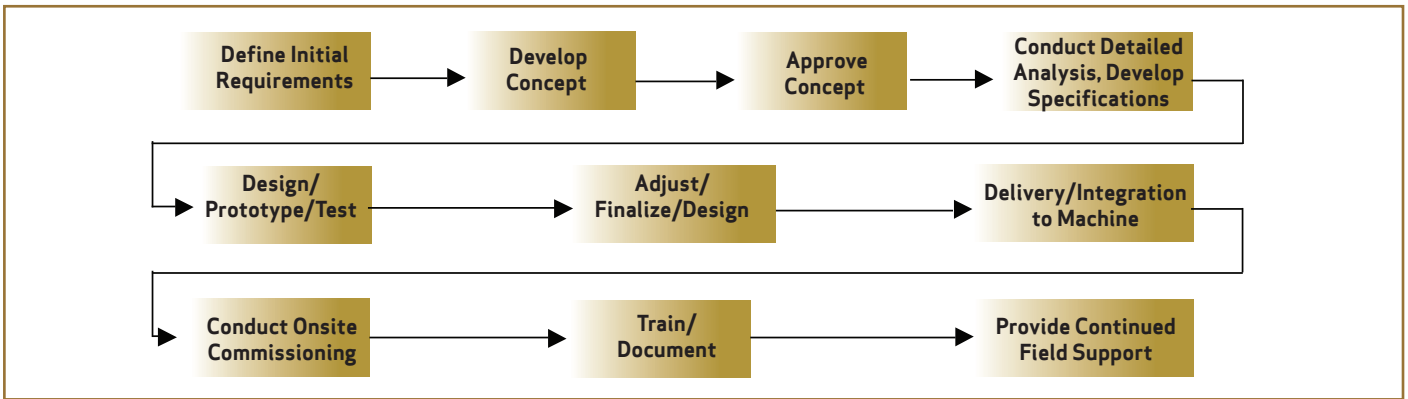

Figure 2 – The Moog Solution - Structured, Partnership-Oriented Engagement Model

4.2 Current Problem, Next-generation Solution

Moog worked with the manufacturer’s engineers and managers to define requirements, understand needs, and ensure that the customer was involved from the outset. Once they had agreed to begin work, Moog put its **Structured, Partnership-Oriented Engagement** model in motion.

Figure 2 depicts typical project phases. In any engagement, Moog takes either a leading or a cooperative role, depending on the customer’s situation, requirements, and preferences. In this power generation example, the manufacturer was willing to share confidential details and develop the solution together with Moog. (Some customers may prefer to keep their motion control solutions in house as part of their core competence. Moog is able to accommodate this preference as well.)

Both formally and informally over a period of weeks, Moog worked with the gas turbine manufacturer to define *initial requirements* for forces, speeds, positioning, accuracy and all other parameters associated with fail-safe operation of the valve.

During *concept development*, Moog looked at the desired outcome first, and then surprised the customer with a viable electro-mechanical solution, contradicting the conventional wisdom that the industry was not yet ready to move beyond electro-hydraulics. This marked a turning point in the project, with revolutionary potential.

Power Generation Application – Technical Challenges

- Fire/Explosion hazard posed by highly pressurized (200 bar) oil and high ambient temperature EH
- Multiple points of failure in hydraulic power unit EH
- Proposed EM solutions limited by traditional thinking: oversized spring in load path, unreliable back-driving of actuator spindle, potential for jammed valve or delayed closure

Analyzing the problem with Moog’s tools and expertise in mechanics, the partners stepped back and saw the bigger opportunity of decentralizing valve control from the main turbine controller. The broadened perspective impressed the customer’s engineers. It demonstrated that Moog was focusing not on merely selling a component, but on working together for an overall motion control solution.

Furthermore, the close cooperation between the manufacturer’s and Moog’s engineers during *Design/Prototype/Test* changed the relationship from the customer-supplier model typical of the industry to a true collaborative partnership. This level of active participation kept the engineers and their organization engaged for the life of the project, and ensured that the solution would meet expectations.

The result of this collaboration is a two-part system with compact actuators, as shown in Figure 3. The first part was the normal operation of precise position control of the opening and closing of the valve, according to the target position provided by the turbine controller. The second part, implemented for safety, was a spring arrangement compressed during a reference movement and locked in place by the use of a magnetic clutch when the valve was in safe mode.

In keeping with the shared approach to this project, Moog was on site for the first test on the customer’s turbine, delivering and installing a production-ready prototype of the new solution, and ensuring that it worked as the team expected.

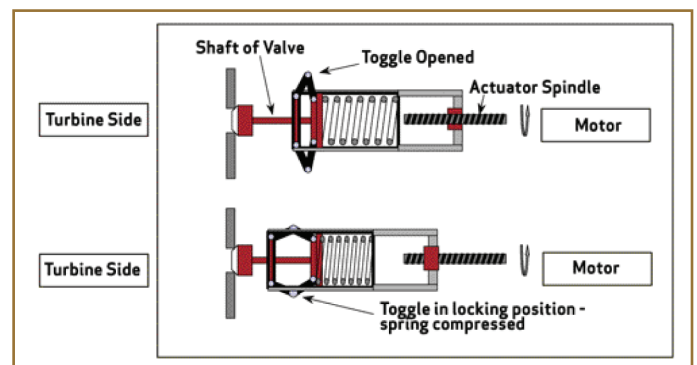

Figure 3 – Fail-safe Mechanism, Gas Turbine Valve

Application Highlight - Injection Molding

| | |
|--------------------------------------|---|
| Customer | Jinhwa Glotech Co., Ltd. |
| Application | Injection unit for molding thin-walled parts for cellular phones, connectors and electrical components. |
| Requirements | Extra power and better dynamics to enable both higher maximum injection speed and more accurate profile. |
| Prevalent Technology | Hydraulic/Electric/Hybrid |
| Challenge | Hydraulic systems meet the needs of high force and speed, but have a large footprint and stiff maintenance requirements. However, in traditional all-electric injection molding machines, ball screw/timing belt mechanisms suffer from inertia and friction under high-load, high-speed conditions, reducing MTBM (minimum time before maintenance) to about one-tenth that of standard machines. Furthermore, plastics manufacturers need to optimize the usage of increasingly expensive resin material. |
| Solution | The all-electric unit reduces inertia by using a gearbox and a high-torque, direct-drive servomotor to translate rotational energy to linear energy and drive the injection screw. The gearbox extends MTBM to approximately 30,000 hours. Feedback from a load cell controls injection pressure for precise transfer between injection and holding phases, allowing tighter tolerances on the process, resulting in lower consumption of plastic resin. |
| Benefits to OEM and end users | Moog provided end-to-end support for Jinhwa Glotech, from design through deployment. The resulting system offers up to 630kN of clamping force and 31kW of injection power at injection speeds of 270mm/sec, and high holding pressure for unlimited periods of time. Tighter tolerance on shot weight results in less consumption and waste of raw material. |
| For More Information | Subscribe at www.info.moog.com for entire case study. |

4.3 Benefits to the OEM

The turbine manufacturer found several benefits in the Moog solution which had been missing from previous attempts with other suppliers.

To address the shortcomings of previous electro-mechanical designs, Moog demonstrated **Willingness to Adapt** to the manufacturer's needs by providing a servodrive, servomotor and actuator of ideal size. The fail-safe design allowed Moog to offer components sized for normal process forces, eliminating the higher cost and package size required by a conventional design sized for both normal and fail-safe forces. The fail-safe mechanism is triggered by the loss of power to the magnetic clutch, shortening the valve closure time through lower acceleration-mass and eliminating the need for the actuation system to back-drive the spindle. The turbine manufacturer enjoyed a strong competitive advantage as a result of a solution tailored to its specific needs.

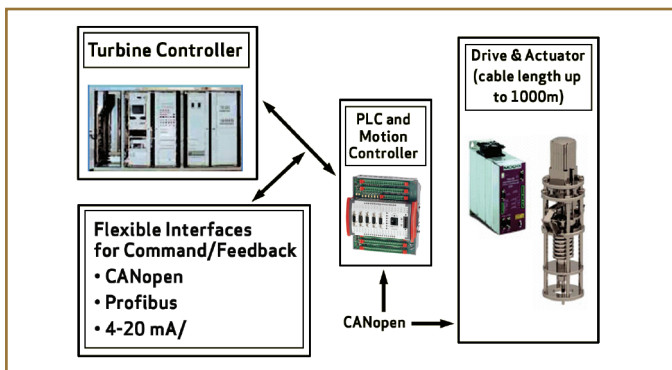

Figure 4 - Architecture and Communication, Power Generation Application

The new way of controlling the actuator (see Figure 4) eliminates pneumatic and hydraulic auxiliary systems.

The main turbine controller now transmits the target position to a connected PLC (Programmable Logic Controller) and Motion Controller (servocontroller), which in turn communicates over CANopen with a servodrive that closes the position loop of the actuator. Moog's **Innovative and Flexible** system allows for multiple interfaces (CANopen, Profibus, 4-20 mA) for command and feedback between the turbine controller and the servocontroller. Furthermore, this decentralized control architecture will work with multiple brands of turbine controller, allowing the manufacturer to choose among suppliers. The solution comprises controllers with special software, long cables to reach controllers up to 1000 meters away, explosion-proof servomotors, and an actuator system tolerant of shock, vibration and high temperature – a true challenge for any motion control solution provider.

Global support is a priority for this manufacturer, who relies on Moog's **Worldwide Reach**: an international network of engineering expertise combined with power generation know-how and a global installed base of motion control systems.

Finally, Moog brought **Business Expertise** to what may have seemed like a pure engineering problem to most suppliers. A fail-safe mechanism this robust makes a multi-million-dollar gas turbine run more safely and cost-effectively. The ultimate contribution to its customer's bottom line is the collaboration that has taken the manufacturer one large step closer to the all-electric turbine, solidifying an important advantage in the power generation marketplace.

5 Conclusion - Partners, not Just Parts

By focusing on the desired outcome rather than on any particular product or technology, Moog specializes in co-developing next-generation motion control solutions with its customers. Working with Moog, manufacturers have access to true leadership in motion control, resulting in strong competitive advantage and the highest levels of machine performance.

6 Information

Moog brings years of expertise to maximize machine productivity and ensure higher performance in motion control applications. Our global team of engineers is always available to collaborate with you on designing a motion control solution that will meet your requirements.

Subscribe to our newsletter and upcoming white papers at www.info.moog.com to learn more about Moog's motion control solutions. For personal consultative expertise, contact a Moog representative in your region.

AMERICAS

Phone +1 716 652 2000 (USA)

EUROPE

Phone +49 7031 622 0 (Germany)

Phone +39 0332 421 111 (Italy)

PACIFIC

Phone +86 21 2893 1600 (China)

Phone +81 463 55 3615 (Japan)

For your nearest Moog location, visit www.moog.com/industrial/globallocator

www.moog.com/industrial

©2008 Moog, Inc.

Moog is a registered trademark of Moog Inc. All trademarks as indicated herein are the property of Moog Inc. and its subsidiaries. All rights reserved.

Mr. Luong White Paper
TJWhite/0108

Author Biography

Robert Luong, product marketing manager for hydraulic products with Moog Industrial, has been with Moog since 2001, working in systems/applications in the U.S., Japan and Germany. He holds bachelor's and master's degrees in electrical engineering from the Ruhr University in Bochum, Germany, an MBA from the ESSEC & Mannheim Business School and over ten years of experience in automation technology.

Contributions provided by:

Thomas Czeppel, Manager Electric Systems, Moog GmbH (Germany)

Dan Halloran, Manager Controls and Electronics, Moog ICD (U.S.)

Roy Park, Managing Director, Moog Australia P/L (Australia)

Ian Whiting, Senior Engineer, Moog Controls Ltd. (U.K.)